

## » SRW02

Wireless window contact

**thermokon**<sup>®</sup>  
HOME OF SENSOR TECHNOLOGY

### Datasheet

Subject to technical alteration  
Issue date: 13.01.2020 • A103

Available in  
▪ pure white brilliant  
▪ anthracite



### » APPLICATION

Battery-free wireless window contact for condition monitoring of windows and doors. Reduces energy consumption through demand-based heating or cooling.

### » TYPES AVAILABLE

#### Radio Door/Window Contact

SRW02 (EEP D5-00-01)

### » SECURITY ADVICE – CAUTION



The installation and assembly of the device should only be performed by authorized personnel.

The product should only be used for the intended application. Unauthorised modifications are prohibited! The product must not be used in relation with any equipment that in case of a failure may threaten, directly or indirectly, human health or life or result in danger to human beings, animals or assets. Ensure all power is disconnected before installing. Do not connect to live/operating equipment.

Please comply with

- Local laws, health & safety regulations, technical standards and regulations
- Condition of the device at the time of installation, to ensure safe installation
- This data sheet and installation manual

### » NOTES ON DISPOSAL



As a component of a large-scale fixed installation, Thermokon products are intended to be used permanently as part of a building or a structure at a pre-defined and dedicated location, hence the Waste Electrical and Electronic Act (WEEE) is not applicable. However, most of the products may contain valuable materials that should be recycled and not disposed of as domestic waste. Please note the relevant regulations for local disposal.

» GUIDELINES FOR DEVICES WITH SOLAR ENERGY STORAGE

Due to the energy-optimized EnOcean radio technology used in "EasySens" wireless sensors, the devices can work without batteries and self-charge themselves using electric energy generated by integrated solar cells. This makes the devices almost maintenance free and environmentally sound due to not having to replace batteries.

For optimum use, the device should be mounted in a location with sufficient ambient brightness. Minimum illumination of 200 lx (artificial light or ambient) is required for at least 3 to 4 hours each day. (The health and safety regulations at work require a minimum illumination of 500 lx for office workplaces).

The solar cell should be mounted facing towards the window direction if possible. If the device has a temperature sensor, then even periodic direct sun radiation should be avoided due to incorrect false temperature readings.

The mounting position should be selected so that the device will not be obstructed in the future: for example by placement areas, additional furniture or roll-fronted cupboards.

The sensor is supplied in an operational state. If the sensor has been stored in darkness for longer periods, the internal solar energy storage will most likely need to be recharged. This would normally happen automatically during commissioning or during initial start up in ambient light. If the initial charge is not sufficient, the sensor will reach its full operating state up to 3 to 4 days, if the requirements for minimum illumination per day are met. The sensor will then transmit continuously in darkness as specified f (2/3 days on factory default telegram timing). Depending on the application it is also possible for the devices to operate in darker rooms (with brightness <100 lx) by using the battery back-up option. Batteries to be used are listed in accessories.

The operating time when using batteries will depend on the transmission frequency as well as the component aging and the self-discharge of the battery. Standard operating time will be 5-10 years on factory default telegram timing. Changing of the device from solar to battery operation is done automatically by simply adding a battery to the device.

» INFORMATION ABOUT EASYSSENS® (RADIO) / AIRCONFIG GENERAL USAGE



EasySens® - airConfig

Basic information about EasySens® radio and about general usage of our airConfig software, please download from our website.

» TECHNISCHE DATEN

Radio technology	EnOcean (IEC 14543-3-10)
Frequency	868 MHz, optional:, 902 MHz
Antenna	internal transmitting/receiving antenna
Power supply	solar cell, internal super cap, maintenance-free, coin cell CR1225 (optional)
Sending interval	at status change, otherwise every 1000 sec.
Sensor	Reed contact and magnet
Enclosure	PC/ABS, pure white or anthracite (optional)
Protection	IP40 according to DIN EN 60529
Ambient condition	-20..+60 °C, max. 85% rH non-condensing
Mounting	to be mounted flat onto the surface using adhesive foil (included) or screws, installation is also possible using mounting base

» PRODUCT TESTING AND CERTIFICATION



Declaration of conformity

The declaration of conformity of the products can be found on our website <https://www.thermokon.de/>.

## » OVERVIEW OF THE RADIO TELEGRAMS



### EEP

The structure of the data contained in the telegram can be found in the EEP (EnOcean equipment profile) list provided by the EnOcean Alliance.

## » MONTAGE

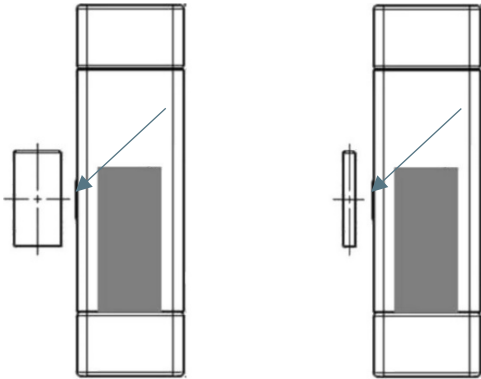

Mounting is optionally performed with the adhesive film or the mounting base included in the delivery. For simplified cleaning and maintenance, the mounting base is recommended.

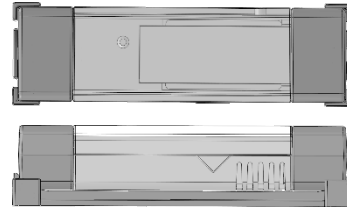

The reed contact unit and the magnet can easily be mounted on windows or door frames made of aluminum, plastic or wood using the supplied adhesive pads. The installation position of the reed contact unit is horizontal, vertical or even inclined.

### Magnet

The very flat magnet can easily be mounted on a smooth surface with the pre-installed adhesive tape. The magnet must be positioned so that it faces the housing near (max 4mm) the reed contact mark.

## » TEACH-IN

By default, a 1BS teach-in telegram is sent by pressing the LRN key. Press the button behind the hole in the side panel of the housing to trigger a teach-in telegram. In sufficiently dark environments, an LED is visible as a telegram display through the side wall of the housing.

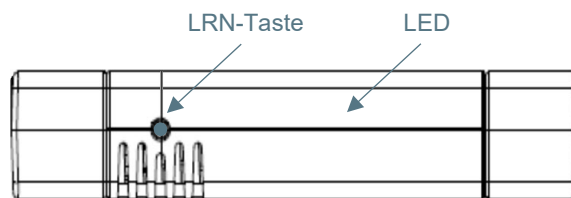

When the LRN key is pressed, the module sends a teach-in telegram to a suitable receiver. The teach-in telegram identifies the device manufacturer, the function and the type of device.

## » INSTALL ADDITIONAL BATTERY (OPTIONAL)

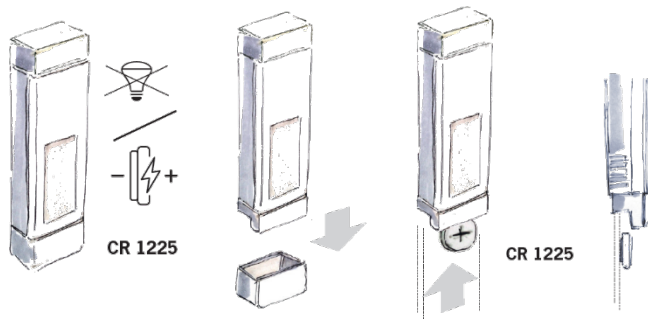

If the sensor is installed in a location where the light intensity is constantly too low, a button cell can be used to supplement the harvester. Use only CR1225 button cells.

1. Remove the cap, which is directly against the solar cell.
2. Insert the battery with the larger positive pole (+) in the direction of the solar cell and slide the slider between the two contact terminals.
3. Replace the cap.

## » DIMENSIONS (MM)

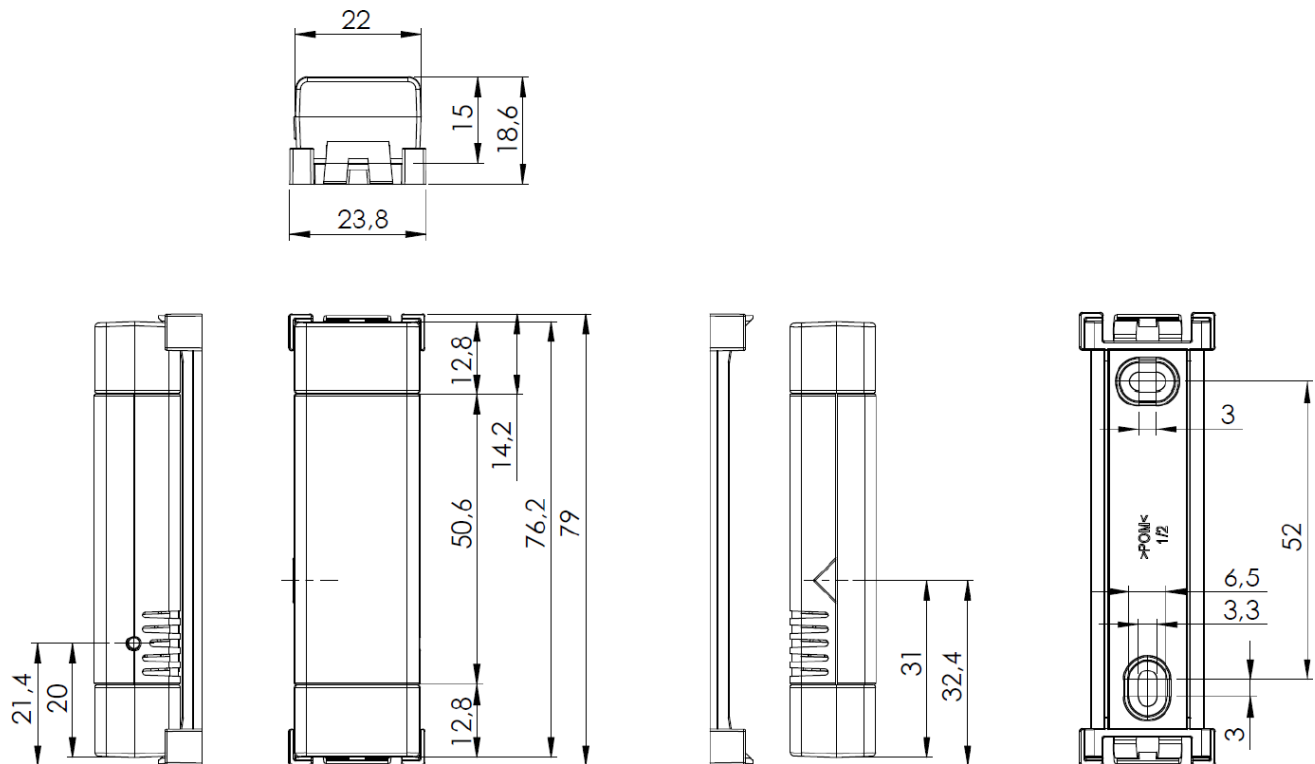

## » ACCESSORIES (OPTIONAL)

Coin cell CR1225

Item No. 727310